





**VIGOR LINE**

2025

*Professional Cleaning Machines*

 Affidabili, compatti e maneggevoli. Gli aspirapolvere Ketek sono in grado di rispondere alle esigenze degli operatori professionali. Dotati di sistemi di filtrazione altamente performanti per garantire efficienza e prestazioni eccellenti.

 Compact, reliable and highly maneuverable. Ketek dry vacuum cleaners are able to meet the needs of professional operators. Equipped with professional filtering systems to ensure the best in terms of efficiency and performance.

 Fiable, compact et facile à manipuler. Les aspirateurs Ketek sont conçus pour répondre aux besoins des opérateurs professionnels. Equipé de systèmes de filtration haute performance pour garantir une efficacité et une performance excellentes.



 Ketek è per il rispetto dell'ambiente, utilizza materie prime eco-sostenibili.

 Ketek respects the environment, uses eco-sustainable raw materials.

 Ketek respecte l'environnement, utilise des matières premières éco-durables.

## LEGEND OF ARTICLE CODES

<b>V</b> Vigor	<b>S</b> Star filter	<b>B</b> Base	<b>4T</b> Three-phase
<b>K</b> Cartridge Filter	<b>M</b> Handle	<b>2M</b> Single phase	<b>BK</b> Bake
<b>N</b> Normal Filter	<b>C</b> Lid	<b>3T</b> Three-phase	

### UNA RETE GLOBALE

I prodotti sono progettati e realizzati interamente nell'impianto produttivo di Manerbio (Brescia). una rete globale di importatori e distributori è presente sui cinque continenti. Ketek ha infatti una forte vocazione internazionale, testimoniata dalla quota di export che ogni anno si attesta attorno al 80% del fatturato. Sono oltre 60 i paesi nel mondo raggiunti dalla rete distributiva di Ketek

### A GLOBAL NETWORK

All products are developed and produced in their entirety within the manufacturing plant located in Manerbio, Brescia Italy. Ketek have a global network of dealers and importers spread worldwide. Ketek share of export is around 80% of its turnover. Our products are distributed in more than 60 countries.

### UN RÉSEAU MONDIAL

Tous les produits sont développés et fabriqués intégralement dans l'usine de fabrication située à Manerbio, Brescia, Italie. Le groupe Ketek dispose d'un réseau mondial de revendeurs et d'importateurs répartis dans le monde entier. La part du groupe Ketek dans les exportations représente environ 80% de son chiffre d'affaires. Nos produits sont distribués dans plus de 60 pays.

 Grazie alla costante attenzione dedicata alla qualità ed all'innovazione siamo certificati ISO9001:2008 Oltre al marchio CE, i modelli di nostra produzione sono altresì certificati IECC - IECE CB SCHEME riconosciuti in tutto il mondo

 Thanks to the constant attention dedicated to quality and innovation we are ISO9001: 2008 certified In addition to the CE, our production models are also IECC - IECE CB SCHEME recognized worldwide.

 Grâce à l'attention constante portée à la qualité et à l'innovation, nous sommes certifiés ISO9001: 2008 En plus de la marque CE nos modèles de production sont également reconnus dans le monde entier par IECC - IECE CB SCHEME.



Designed & Manufactured in Italy



## PRODUZIONE UNA REALTÀ INDUSTRIALE

Ketek incorpora al meglio tutti i valori dell'industria italiana:

- Passione autentica per il risultato finale del lavoro svolto
- Inserimento in un tessuto produttivo diffuso e "di filiera"
- Progettazione e produzione fortemente integrate
- Flessibilità e naturale predisposizione al cambiamento
- Ottima velocità di risposta alla richiesta del mercato

### VISION

- Trasferire nei prodotti finiti le capacità delle persone
- Agire con onestà e serietà nelle relazioni con clienti e fornitori
- Creare valore per azionisti, clienti e dipendenti
- Rispondere alle molteplici e sempre più esigenti richieste del mercato
- Diventare un punto di riferimento per gli operatori del cleaning professionale

### MISSION

Garantire il migliore rapporto qualità-prezzo dei prodotti offerti attraverso una continua ricerca industriale applicata e l'ottimizzazione dei sistemi produttivi esistenti.

### LA PRECISIONE NELL'ASSEMBLAGGIO

Ketek opera mediante linee di produzione suddivise per prodotto di riferimento. La precisione nel processo produttivo passa, innanzitutto, attraverso la specializzazione della forza lavoro disponibile.

Lo stabilimento di produzione ospita attualmente al proprio interno i seguenti reparti:

- 3 linee per l'assemblaggio di aspirapolvere, aspiratori solidi-liquidi e lavamoquette
- 1 linea per l'assemblaggio di generatori di vapore

### LA STRADA PER LA QUALITÀ

La qualità costituisce l'obiettivo principale che Ketek intende perseguire mediante le proprie attività.

Il mantenimento della qualità è la ragione per la quale l'azienda ogni anno investe una parte consistente delle proprie risorse in Ricerca & Sviluppo.

Non rinunciare al posizionamento nella fascia più alta delle macchine professionali per la pulizia indoor è il risultato.

Un reparto con personale altamente specializzato e dipendenti sono impegnati costantemente nella concretizzazione di nuove idee, nello studio di ritrovati all'avanguardia e nella progettazione di nuovi modelli. È qui che si danno risposte ai bisogni e alle richieste di oggi, è qui che si anticipano le esigenze del mercato di domani.

Un gruppo di ingegneri, coadiuvato da tecnologie all'avanguardia, è costantemente al lavoro per perfezionare l'esistente e progettare il nuovo.

Si studiano soluzioni innovative non soltanto per migliorare continuamente le funzionalità e l'ergonomia delle macchine Ketek ma altresì per ridurre la rumorosità, per migliorarne il risparmio energetico, nonché per rendere le medesime sempre più efficienti, versatili e robuste ricorrendo ai materiali ed alle tecnologie più idonee allo scopo. L'intero processo produttivo si ispira alle migliori prassi oggi esistenti per tutelare l'ambiente.



## MANUFACTURING INDUSTRIAL REALITY

Ketek boasts the traditional values which belong to the Italian industry:

- passion for work results
- strongly linked planning and production activities
- flexibility and openness to change
- being fast in responding to market requirements

### VISION

Transferring people's expertise into our products. Working honestly and acting seriously with clients and suppliers. Creating value for shareholders, clients and employees. Coping with and responding to the increasingly growing market requirements. Becoming a point of reference for all professionals in the cleaning sector.

### MISSION

Ensuring the best quality-price ratio by means of a continuous industrial research and the constant optimization of the production systems.

### ASSEMBLY PRECISION

Each Ketek production line is set for a single product. The high-quality production process is reflected by the highly specialized workforce.

- 3 lines are for the assembly of vacuum cleaners, wet-dry vacuum cleaners and spray-extraction cleaners
- 1 line is for the assembly of steam generators

### THE WAY TO QUALITY

Quality is Ketek main purpose.

Maintaining competitiveness in its sector is the reason why every year our company invests a large amount of its resources in Research & Development.

The ambition of not giving up our position in the highest level of professional machines for indoor cleaning is the end result. A highly specialised department is constantly in charge of turning new ideas into reality by means of regular updates regarding new technologies and the development of new models as well. It is indeed in the R&D department that our products are conceived so that they can respond well to the latest market requirements. Future needs are predicted in the same area, as well.

A team of engineers, with the support of advanced technologies and employees, is constantly working to improve the existing machines and to develop new ones.

Research is carried out to constantly improve functionality, ergonomics and to reduce noise while focusing on energy saving. We search for new materials and technologies which can make Ketek machines increasingly effective, versatile and strong while fully respecting the environment



## PRODUCTION UNE RÉALITÉ INDUSTRIELS

Ketek incorpore au mieux toutes les valeurs de l'industrie italienne :

- Passion authentique pour le résultat final du travail accompli
- Insertion dans un tissu productif répandu et « de filière »
- Conception et production fortement intégrées
- Flexibilité et prédisposition naturelle au changement
- Rapidité de réponse excellente aux demandes du marché

### VISION

- Transférer dans les produits finis les capacités des personnes
- Agir avec honnêteté et sérieux vis-à-vis de clients et fournisseurs
- Créer de la valeur pour les actionnaires, les clients et les employés
- Répondre aux multiples et toujours plus exigeantes demandes du marché
- Devenir un point de repère pour les opérateurs du nettoyage professionnel

### MISSION

Garantir le meilleur rapport qualité-prix des produits offerts à travers une recherche industrielle appliquée continuelle et l'optimisation des systèmes de production déjà existants.

### LA PRÉCISION DANS LE MONTAGE

Ketek dispose de lignes de production divisées par produit de référence. La précision dans le processus de production passe, tout d'abord, par la spécialisation de la main-d'œuvre disponible. L'usine de production abrite actuellement les départements suivants :

- 3 lignes pour l'assemblage d'aspirateurs, aspirateurs solides-liquides et lave-moquettes
- 1 ligne pour l'assemblage des générateurs de vapeur

### LA ROUTE POUR LA QUALITÉ

La qualité est l'objectif principal que Ketek entend poursuivre à travers ses activités.

Le maintien de la qualité est la raison pour laquelle l'entreprise investit chaque année une part substantielle de ses ressources dans la recherche et le développement.

Le résultat : ne pas abandonner le placement dans la plus haute gamme de machines professionnelles de nettoyage d'intérieur.

Un service disposant d'un personnel hautement spécialisé et collaborateurs sont constamment engagés dans la réalisation de nouvelles idées, dans l'étude de découvertes avant-gardistes et dans la conception de nouveaux modèles. C'est ici qu'on donne les réponses aux besoins et aux demandes d'aujourd'hui ; c'est ici qu'on anticipe les besoins du marché de demain.

Un groupe d'ingénieurs, assisté par des technologies de pointe, travaille constamment à perfectionner l'existant et à concevoir le nouveau.

Des solutions innovantes sont étudiées non seulement pour améliorer continuellement la fonctionnalité et l'ergonomie des machines Ketek mais aussi pour réduire les niveaux de bruit, améliorer les économies d'énergie et les rendre de plus en plus efficaces, polyvalentes et robustes, en utilisant les matériaux et technologies les plus appropriées à cet effet. L'ensemble du processus de production est inspiré par les meilleures pratiques qui existent aujourd'hui pour protéger l'environnement.

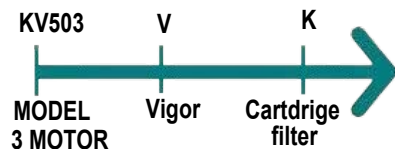
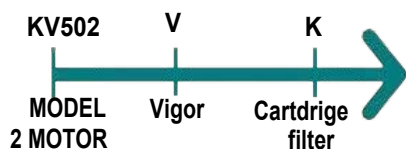

	<b>KV502VK</b>	<b>KV503VK</b>
Potenza/Power/Puissance	2x1200W - 1400W max	3x1200W - 1400W max
Voltaggio/Voltage/Tension	220-240V/50-60Hz	220-240V/50-60Hz
Motore/Motors/Moteurs	2xDouble Stage Bypass	3xDouble Stage Bypass
Cavo elettrico/Power cable/Câble	10 mt	10 mt
Depressione/Waterlift/Dépression	2400 mm H2O	2400 mm H2O
Portata/Air flow/Débit d'air	450 m3/h	650 m3/h
Capacità/Capacity/Capacité	75 Lt.	75 Lt.
Fusto/Tank/Cuve	Inox	Inox
Peso/Weight/Poids	28 kg	29 kg
Emissioni acustiche/Sound level/Niveau sonore	68 dB (A)	70 dB (A)
Dimensioni Imballo/Box Dimension/Dimensions	570 x 570 x 1400	570 x 570 x 1400
Pezzi Bancale/Pieces pallet/Pièces palette	4	4
Dimensioni Bancale/Pallet/Palette	1200 x 1200 x h1600	1200 x 1200 x h1600

1	Manicotto zinc. bocchet.tang.d.50	Standard	AMLBTNG50D
2	Spazzola pavimenti/Steel Nozzle/Étage suceur	Optional	ASP450L50D
3	Tubo Prolunga Cromato "S"/Chrome Suction Tube "S"/Canne coude	Optional	ATPC2S50D
4	Ciclone/Cyclon/Cyclone	Standard	ACY040
5	Separatore trucioli/Chiop separator/Separateur copeaux KV502VK-KV503VK	Optional	AST330H375L
6	Cesta Porta Accessori/Accessory Basket/ Panier porte accessoires	Optional	APDGR



**Accessori/Accessories/Accessoires Ø50 KACCK50VG**

			Code
7	Tubo flessibile antistatico mt2,5/Antistatic complete hose mt2,5/Antistatique complet flexible mt2,5	Optional	KTFC25M50D
8	Lancia Piatta antistatica/Antistatic crevice tool/Antistatique plat suceur	Optional	ALPA50D
9	Lancia conica antistatica/Antistatic conic tool/Antistatique conique suceur	Optional	ALCA50D
10	Lancia per fessure antistatica/Antistatic Conic Crevice Tool	Optional	ALFA50D
11	Lancia piatta zincata/Plated Crevice Tool/Zinguè plat suceur	Optional	ALPZ50D
12	Raccordo per accessori zincato/Plated Coupling/Zinguè suceur réducteur	Optional	ARZA50D



**Accessori/Accessories/Accessoires Ø40 KACCK40V**

			Code
13	Flessibile Completo mt2,5/Complete Hose mt2,5/Complet flexible mt2,5	Optional	KTFC25M40D
14	Tubo Prolunga Cromato "S"/Chrome Suction Tube "S"/Canne double coude	Optional	ATPC2S40D
15	Lancia Piatta/Crevice Tool/Suceur Plat	Optional	ALP40D
16	Manicotto riduttore/Reducer rubber sleeve/Manchon de réduction en caoutchouc D50-D40	Optional	AMTEA40D
17	Pennello/Round Brush/Brosse ronde	Optional	APN40D
18	Spazzola Pavimenti Polvere/Nozzle Hard Floor/Suceur poussière	Optional	ASP40D
19	Spazzola Pavimenti Liquidi/Nozzle Wet Floor/Suceur Eau	Optional	ASL40D



**Filtri/Filters/Filtre**

		cm²		Code
A	Filtro Cartuccia/Cartridge Filter/Cartouche	15.000	Standard	FCPACY



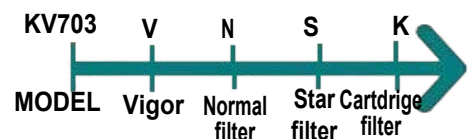
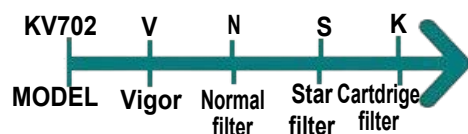

KETEK  
 CLEANING PROVIDER

**KV702VN  
 KV702VS  
 KV702VK**

**KV703VN  
 KV703VS  
 KV703VK**

Potenza/Power/Puissance	2x1200W - 1400W max	3x1200W - 1400W max
Voltaggio/Voltage/Tension	220-240V/50-60Hz	220-240V/50-60Hz
Motore/Motors/Moteurs	2xDouble Stage Bypass	3xDouble Stage Bypass
Cavo elettrico/Power cable/Câble	10 mt	10 mt
Depressione/Waterlift/Dépression	2400 mm H2O	2400 mm H2O
Portata/Air flow/Débit d'air	450 m3/h	650 m3/h
Capacità/Capacity/Capacité	85 Lt.	85 Lt.
Fusto/Tank/Cuve	Inox	Inox
Peso/Weight/Poids	50 kg	52 kg
Emissioni acustiche/Sound level/Niveau sonore	68 dB (A)	70 dB (A)
Dimensioni Imballo/Box Dimension/Dimensions	600 x 800 x 1800	600 x 800 x 1800
Pezzi Bancale/Pieces pallet/Pièces palette	1	1
Dimensioni Bancale/Pallet/Palette	800 x 1200 x h2000	800 x 1200 x h2000

1	Manicotto zinc. bocchet.tang.d.50	Standard	AMLBTNG50D
2	Spazzola pavimenti/Steel Nozzle/Étage suceur	Optional	ASP450L50D
3	Tubo Prolunga Cromato "S"/Chrome Suction Tube "S"/Canne coude	Optional	ATPC2S50D
4	ciclone/Cyclon/Cyclone mod. KV702VK-KV703VK	Standard	ACY040
5	Separatore trucioli/Chiop separator/Separateur copeaux KV702VK-KV703VK	Optional	AST330H375L



**Accessori/Accessories/Accessoires Ø50 KACCK50VG**

			Code
6	Tubo flessibile antistatico mt2,5/Antistatic complete hose mt2,5/Antistatique complet flexible mt2,5	Optional	KTFCA25M50D
7	Lancia Piatta antistatica/Antistatic crevice tool/Antistatique plat suceur	Optional	ALPA50D
8	Lancia conica antistatica/Antistatic conic tool/Antistatique conique suceur	Optional	ALCA50D
9	Lancia per fessure antistatica/Antistatic Conic Crevice Tool	Optional	ALFA50D
10	Lancia piatta zincata/Plated Crevice Tool/Zinguè plat suceur	Optional	ALPZ50D
11	Raccordo per accessori zincato/Plated Coupling/Zinguè suceur réducteur	Optional	ARZA50D



**Accessori/Accessories/Accessoires Ø40 KACCK40V**

			Code
12	Flessibile Completo mt2,5/Complete Hose mt2,5/Complet flexible mt2,5	Optional	KTFC25M40D
13	Tubo Prolunga Cromato "S"/Chrome Suction Tube "S"/Canne double coude	Optional	ATPC2S40D
14	Lancia Piatta/Crevice Tool/Suceur Plat	Optional	ALP40D
15	Manicotto riduttore/Reducer rubber sleeve/Manchon de réduction en caoutchouc D50-D40	Optional	AMTEA40D
16	Pennello/Round Brush/Brosse ronde	Optional	APN40D
17	Spazzola Pavimenti Polvere/Nozzle Hard Floor/Suceur poussière	Optional	ASP40D
18	Spazzola Pavimenti Liquidi/Nozzle Wet Floor/Suceur Eau	Optional	ASL40D



**Filtri/Filters/Filtre**

		cm <sup>2</sup>		Code
A	Filtro Tela/Textile Filter/Tis-su filtre mod. 702VN/703VN	8.000	Standard	KFILPG
B	Filtro Antischiuma/Anti Foam Filter/Anti moussant filtre mod. 702VN/703VN	/	Standard	FASC1M
C	Filtro tela Stellare/Star Filter/Star Canvas filter/filtre étoile mod. 702VS/703VS	11.000	Standard	KFILPST
D	Filtro Cartuccia/Cartridge Filter/Carbouche mod. 702VK/703VK	15.000	Standard	FCPACY
E	Tendi filtro/Filter tensioner/Tendeur de filtre (mod. A - C)	/	Standard	TFTPGS

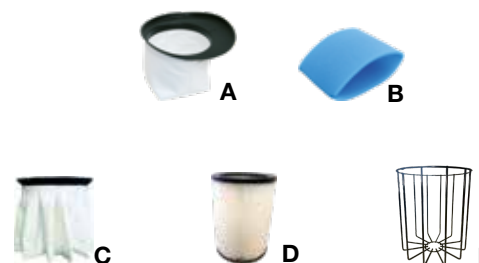

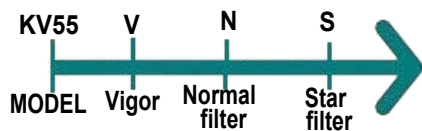

**KV55V2MN**  
**KV55V2MS**

**KV55V3TN**  
**KV55V3TS**

**KV55V4TN**  
**KV55V4TS**

Potenza/Power/Puissance	2,200 W P. max 3CV	3,000 W P. max 4CV	4,000 W P. max 5,5CV
Voltaggio/Voltage/Tension	220-240V/50-60Hz	400V/50-60Hz	400V/50-60Hz
Motore/Motors/Moteurs	Monofase	Trifase	Trifase
Cavo elettrico/Power cable/Câble	10 mt	10 mt	10 mt
Depressione/Waterlift/Dépression	max 2800 mm H2O	max 3300 mm H2O	max 3400 mm H2O
Portata/Air flow/Débit d'air	350 m3/h	360 m3/h	370 m3/h
Capacità/Capacity/Capacité	55 Lt.	55 Lt.	55 Lt.
Fusto/Tank/Cuve	Inox	Inox	Inox
Peso/Weight/Poids	60 kg	60 kg	60 kg
Emissioni acustiche/Sound level/Niveau sonore	75 dB (A)	76 dB (A)	76 dB (A)
Dimensioni Imballo/Box Dimension/Dimensions	800 x 500 x 1800	800 x 500 x 1800	800 x 500 x 1800
Pezzi Bancale/Pieces pallet/Pièces palette	1	1	1
Dimensioni Bancale/Pallet/Palette	800 x 1200 x h2000	800 x 1200 x h2000	800 x 1200 x h2000



**Accessori/Accessories/Accessoires Ø40 KACCK40**

**Code**

1	Flessibile Completo mt2,5/Complete Hose mt2,5/Complet flexible mt2,5	Optional	KTFC25M40D
2	Tubo Prolunga Cromato "S"/Chrome Suction Tube "S"/Canne double coude	Optional	ATPC2S40D
3	Lancia Piatta/Crevice Tool/Suceur Plat	Optional	ALP40D
4	Pennello/Round Brush/Brosse ronde	Optional	APN40D
5	Spazzola Pavimenti Polvere/Nozzle Hard Floor/Suceur poussière	Optional	ASP40D
6	Spazzola Pavimenti Liquidi/Nozzle Wet Floor/Suceur Eau	Optional	ASL40D
7	Supporto sacco/Bag holden/porte-sac	Optional	KFILPST
8	Vaschetta con manici/Tray with handle/bac avec poigné	Optional	ASUPSAC



**Filtri/Filters/Filtre**

cm<sup>2</sup>

**Code**

A	Filtro Tela/Textile Filter/Tissu filtre mod. 55V2MN/553TN/554TN	8.000	Standard	KFILPG
B	Filtro Antischiuma/Anti Foam Filter/Anti moussant filtre mod. 55V2MN/553TN/554TN	/	Standard	FASC1M
C	Filtro tela Stellare/Star Filter/Star Canvas filter/filtre étoile mod. 55V2MS/55V3MS/55V4MS	11.000	Standard	KFILPST
D	Filtro Nylon/Nylon Filter/Surfiltre nylon	/	Optional	FNLY3M
E	Sacco Microfibr/Microfiber Bag/Sac microfiber	/	Optional	SACMF50/70L
F	Tendi filtro/Filter tensioner/Tendeur de filtre	/	Standard	TFTPGS

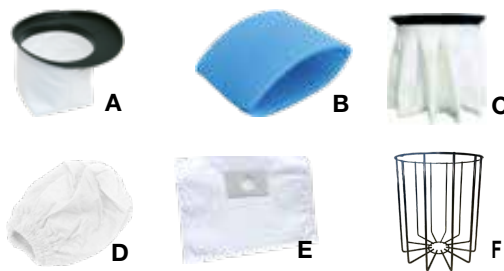

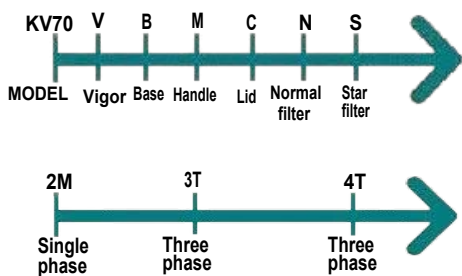

- ① KV70VB2MN KV70VB3TN KV70VB4TN  
KV70VB2MS KV70VB3TS KV70VB4TS
- ② KV70VM2MN KV70VM3TN KV70VM4TN  
KV70VM2MS KV70VM3TS KV70VM4TS
- ③ KV70VC2MN KV70VC3TN KV70VC4TN  
KV70VC2MS KV70VC3TS KV70VC4TS

Potenza/Power/Puissance	2,200 W P. max 3CV	3,000 W P. max 4CV	4,000 W P. max 5,5CV
Voltaggio/Voltage/Tension	220-240V/50-60Hz	400V/50-60Hz	400V/50-60Hz
Motore/Motors/Moteurs	Monofase	Trifase	Trifase
Cavo elettrico/Power cable/Câble	10 mt	10 mt	10 mt
Depressione/Waterlift/Dépression	max 2800 mm H2O	max 3300 mm H2O	max 3400 mm H2O
Portata/Air flow/Débit d'air	350 m3/h	360 m3/h	370 m3/h
Capacità/Capacity/Capacité	75 Lt.	75 Lt.	75 Lt.
Fusto/Tank/Cuve	Inox	Inox	Inox
Peso/Weight/Poids	65 kg	65 kg	65 kg
Emissioni acustiche/Sound level/Niveau sonore	75 dB (A)	76 dB (A)	76 dB (A)
Dimensioni Imballo/Box Dimension/Dimensions	1100 x 470 x 1200	1100 x 470 x 1200	1100 x 470 x 1200
Pezzi Bancale/Pieces pallet/Pièces palette	1	1	1
Dimensioni Bancale/Pallet/Palette	800 x 1200 x h1800	800 x 1200 x h1800	800 x 1200 x h1800

CLEANING PROVIDER

**Accessori/Accessories/Accessoires Ø40 KACCK40**

			Code
1	Flessibile Completo mt2,5/Complete Hose mt2,5/Complet flexible mt2,5	Optional	KTFC25M40D
2	Tubo Prolunga Cromato "S"/Chrome Suction Tube "S"/Canne double coude	Optional	ATPC2S40D
3	Lancia Piatta/Crevice Tool/Suceur Plat	Optional	ALP40D
4	Pennello/Round Brush/Brosse ronde	Optional	APN40D
5	Spazzola Pavimenti Polvere/Nozzle Hard Floor/Suceur poussière	Optional	ASP40D
6	Spazzola Pavimenti Liquidi/Nozzle Wet Floor/Suceur Eau	Optional	ASL40D



**Filtri/Filters/Filtre**

		cm <sup>2</sup>		Code
A	Filtro Tela/Textile Filter/Tissu filtre mod. 70VB2MN/70VB3TN/70VB4TN	8.000	Standard	KFILPG
B	Filtro Antischiuma/Anti Foam Filter/Anti moussant filtre mod. 70VB2MN/70VB3TN/70VB4TN	/	Standard	FASC3M
C	Filtro tela Stellare/Star Filter/Star Canvas filter/filtre étoile mod. 70VB2MS/70VB3TS/70VB4TS	11.000	Standard	KFILPST
D	Filtro Nylon/Nylon Filter/Surfiltre nylon	/	Optional	FNLY3M
E	Sacco Microfibra/Microfiber Bag/Sac microfiber	/	Optional	SACMF50/70L
F	Tendi filtro/Filter tensioner/Tendeur de filtre	/	Standard	TFTPGS



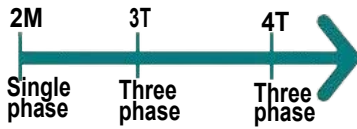
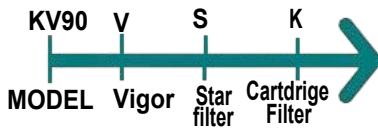

KETEK  
CLEANING PROVIDER

	<b>KV90V2MS</b> <b>KV90V2MK</b>	<b>KV90V3TS</b> <b>KV90V3TK</b>	<b>KV90V4TS</b> <b>KV90V4TK</b>
Potenza/Power/Puissance	2,200 W P. max 3CV	3,000 W P. max 4CV	4,000 W P. max 5,5CV
Voltaggio/Voltage/Tension	220-240V/50-60Hz	400V/50-60Hz	400V/50-60Hz
Motore/Motors/Moteurs	Monofase	Trifase	Trifase
Cavo elettrico/Power cable/Câble	10 mt	10 mt	10 mt
Depressione/Waterlift/Dépression	max 2800 mm H2O	max 3300 mm H2O	max 3400 mm H2O
Portata/Air flow/Débit d'air	350 m3/h	360 m3/h	370 m3/h
Capacità/Capacity/Capacité	95 Lt.	95 Lt.	95 Lt.
Fusto/Tank/Cuve	Inox	Inox	Inox
Peso/Weight/Poids	80 kg	80 kg	80 kg
Emissioni acustiche/Sound level/Niveau sonore	75 dB (A)	76 dB (A)	76 dB (A)
Dimensioni Imballo/Box Dimension/Dimensions	600 x 800 x 1800	600 x 800 x 1800	600 x 800 x 1800
Pezzi Bancale/Pieces pallet/Pièces palette	1	1	1
Dimensioni Bancale/Pallet/Palette	800 x 1200 x h2000	800 x 1200 x h2000	800 x 1200 x h2000

1	Manicotto zinc. bocchet.tang.d.50	Standard	AMLBTNG50D
2	Spazzola pavimenti/Steel Nozzle/Étage suceur	Optional	ASP450L50D
3	Tubo Prolunga Cromato "S"/Chrome Suction Tube "S"/Canne coude	Optional	ATPC2S50D
4	ciclone/Cyclon/Cyclone KV90V2MK-KV90V3TK-KV90V4TK	Standard	ACY040
5	Separatore trucioli/Chiop separator/Separateur copeaux KV90V2MK-KV90V3TK-KV90V4TK	Optional	AST330H420L



Accessori/Accessories/Accessoires Ø50 KACCK50VG		Code	
6	Tubo flessibile antistatico mt2,5/Antistatic complete hose mt2,5/Antistatique complet flexible mt2,5	Optional	KTFC25M50D
7	Lancia Piatta antistatica/Antistatic crevice tool/Antistatique plat suceur	Optional	ALPA50D
8	Lancia conica antistatica/Antistatic conic tool/Antistatique conique suceur	Optional	ALCA50D
9	Lancia per fessure antistatica/Antistatic Conic Crevice Tool	Optional	ALFA50D
10	Lancia piatta zincata/Plated Crevice Tool/Zinguè plat suceur	Optional	ALPZ50D
11	Raccordo per accessori zincato/Plated Coupling/Zinguè suceur réducteur	Optional	ARZA50D



Accessori/Accessories/Accessoires Ø40 KACCK40V		Code	
12	Flessibile Completo mt2,5/Complete Hose mt2,5/Complet flexible mt2,5	Optional	KTFC25M40D
13	Tubo Prolunga Cromato "S"/Chrome Suction Tube "S"/Canne double coude	Optional	ATPC2S40D
14	Lancia Piatta/Crevice Tool/Suceur Plat	Optional	ALP40D
15	Manicotto riduttore/Reducer rubber sleeve/Manchon de réduction en caoutchouc D50-D40	Optional	AMTFA40D
16	Pennello/Round Brush/Brosse ronde	Optional	APN40D
17	Spazzola Pavimenti Polvere/Nozzle Hard Floor/Suceur poussière	Optional	ASP40D
18	Spazzola Pavimenti Liquidi/Nozzle Wet Floor/Suceur Eau	Optional	ASL40D



Filteri/Filters/Filtre	cm <sup>2</sup>	Code	
A Filtro tela Stellare/Star Filter/Star Canvas filter/filtre étoile mod. 90V2MS/90V3T-S/90V4TS	15.500	Standard	FTPVMS
B Filtro Cartuccia/Cartridge Filter/Cartouche mod. 90V2MK/90V3TK/90V4TK	20.000	Standard	FCPACYMVP
C Tendi filtro/Filter tensioner/Tendeur de filtre Mod. 90V4TS	/	Standard	TFTPS230H345L



## ITALY PULIZIA DEL FILTRO

Quando l'apparecchio perde di efficacia aspirante pulire il filtro:

- 1) Chiudere il bocchettone d'aspirazione
- 2) Premere la leva verso il basso per chiudere completamente la valvola (punto 3)
- 3) Sollevare la leva scuoti filtro (punto 3)
- 4) Ripetere il punto 2 e 3 ad intervalli di una decina di secondi.

## ENGLAND CLEANING OF THE FILTER

Clean the filter when the machine loses suction efficiency:

- 1) Block suction
- 2) Press the lever down to close the valve completely (point 2)
- 3) Lift the filter shaker lever (point 3)
- 4) Repeatedly at regular intervals of a few seconds.

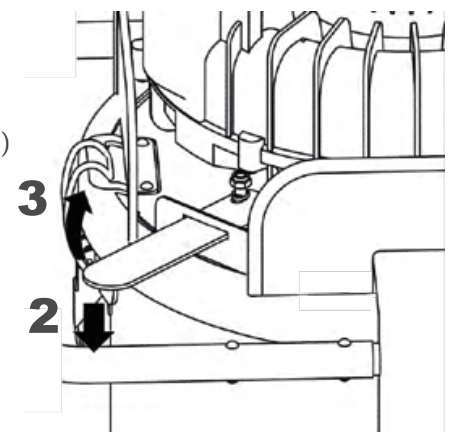

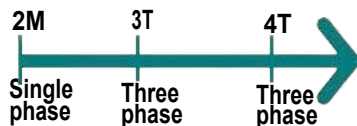
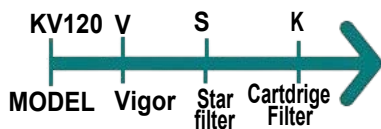

**KV120V2MS KV120V2MK**    **KV120V3TS KV120V3TK**    **KV120V4TS KV120V4TK**

Potenza/Power/Puissance	2,200 W P. max 3CV	3,000 W P. max 4CV	4,000 W P. max 5,5CV
Voltaggio/Voltage/Tension	220-240V/50-60Hz	400V/50-60Hz	400V/50-60Hz
Motore/Motors/Moteurs	Monofase	Trifase	Trifase
Cavo elettrico/Power cable/Câble	10 mt	10 mt	10 mt
Depressione/Waterlift/Dépression	max 2800 mm H2O	max 3300 mm H2O	max 3400 mm H2O
Portata/Air flow/Débit d'air	350 m3/h	360 m3/h	370 m3/h
Capacità/Capacity/Capacité	125 Lt.	125 Lt.	125 Lt.
Fusto/Tank/Cuve	Inox	Inox	Inox
Peso/Weight/Poids	95 kg	95 kg	95 kg
Emissioni acustiche/Sound level/Niveau sonore	75 dB (A)	76 dB (A)	76 dB (A)
Dimensioni Imballo/Box Dimension/Dimensions	900 x 700 x 2100	900 x 700 x 2100	900 x 700 x 2100
Pezzi Bancale/Pieces pallet/Pièces palette	1	1	1
Dimensioni Bancale/Pallet/Palette	800 x 1200 x h2200	800 x 1200 x h2200	800 x 1200 x h2200

1	Manicottto zinc. bocchet.tang.d.50	Standard	AMLBTNG50D
2	Spazzola pavimenti/Steel Nozzle/Étage suceur	Optional	ASP450L50D
3	Tubo Prolunga Cromato "S"/Chrome Suction Tube "S"/Canne coude	Optional	ATPC2S50D
4	ciclone/Cyclon/Cyclone	Optional	ACY040
5	Separatore trucioli/Chiop separator/Separateur copeaux KV702IV-KV703IV	Optional	AST330H460L



Accessori/Accessories/Accessoires Ø50 KACCK50VG			Code
6	Tubo flessibile antistatico mt2,5/Antistatic complete hose mt2,5/Antistatique complet flexible mt2,5	Optional	KTFC25M50D
7	Lancia Piatta antistatica/Antistatic crevice tool/Antistatique plat suceur	Optional	ALPA50D
8	Lancia conica antistatica/Antistatic conic tool/Antistatique conique suceur	Optional	ALCA50D
9	Lancia per fessure antistatica/Antistatic Conic Crevice Tool	Optional	ALFA50D
10	Lancia piatta zincata/Plated Crevice Tool/Zinguè plat suceur	Optional	ALPZ50D
11	Raccordo per accessori zincato/Plated Coupling/Zinguè suceur réducteur	Optional	ARZA50D



Accessori/Accessories/Accessoires Ø40 KACCK40V			Code
12	Flessibile Completo mt2,5/Complete Hose mt2,5/Complet flexible mt2,5	Optional	KTFC25M40D
13	Tubo Prolunga Cromato "S"/Chrome Suction Tube "S"/Canne double coude	Optional	ATPC2S40D
14	Lancia Piatta/Crevice Tool/Suceur Plat	Optional	ALP40D
15	Manicotto riduttore/Reducer rubber sleeve/Manchon de réduction en caoutchouc D50-D40	Optional	AMTFA40D
16	Pennello/Round Brush/Brosse ronde	Optional	APN40D
17	Spazzola Pavimenti Polvere/Nozzle Hard Floor/Suceur poussière	Optional	ASP40D
18	Spazzola Pavimenti Liquidi/Nozzle Wet Floor/Suceur Eau	Optional	ASL40D



Filtri/Filters/Filtre	cm <sup>2</sup>	Code	
A Filtro tela Stellare/Star Fil-ter/ Star Canvas filter/filtre étoile mod. 120V2MS/ 120V3TS/120V4TS	20.000	Standard	FTPVGS
B Filtro Cartuccia/Cartridge Filter/Cartouche mod. 120V2MK/120V3TK/ 120V4TK	20.000	Standard	FCPACYMVP
C Tendi filtro/Filter tensioner/Tendeur de filtre Mod. 120V4TS	/	Standard	TFTPS355H400L



## ITALY PULIZIA DEL FILTRO

Quando l'apparecchio perde di efficacia aspirante pulire il filtro:

- 1) Chiudere il bocchettone d'aspirazione
- 2) Premere la leva verso il basso per chiudere completamente la valvola (punto 3)
- 3) Sollevare la leva scuoti filtro (punto 3)
- 4) Ripetere il punto 2 e 3 ad intervalli di una decina di secondi.

## UK CLEANING OF THE FILTER

Clean the filter when the machine loses suction efficiency:

- 1) Block suction
- 2) Press the lever down to close the valve completely (point 2)
- 3) Lift the filter shaker lever (point 3)
- 4) Repeatedly at regular intervals of a few seconds.

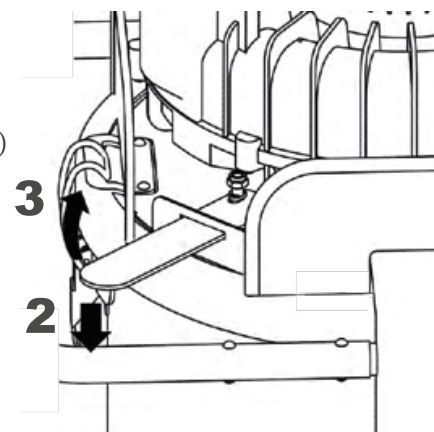





	① KV30BK	② KV501BK	③ KV72BK	④ KV703BK
Potenza/Power/Puissance	1100W - 1200W max	1200W - 1400W max	2x1100W - 1200W max	3x1200W - 1400W max
Voltaggio/Voltage/Tension	220-240V/50-60Hz	220-240V/50-60Hz	220-240V/50-60Hz	220-240V/50-60Hz
Motore/Motors/Moteurs	1xDouble Stage Bypass	1xDouble Stage Bypass	2xDouble Stage Bypass	3xDouble Stage Bypass
Cavo elettrico/Power cable/Câble	10 mt	10 mt	10 mt	10 mt
Depressione/Waterlift/Dépression	2200 mm H2O	2400 mm H2O	2300 mm H2O	2400 mm H2O
Portata/Air flow/Débit d'air	180 m3/h	220 m3/h	350 m3/h	650 m3/h
Capacità/Capacity/Capacité	34 Lt.	55 Lt.	75 Lt.	90 Lt.
Fusto/Tank/Cuve	Inox	Inox Aisi 430	Inox	Inox
Peso/Weight/Poids	12 kg	16 kg	23 kg	52 kg
Emissioni acustiche/Sound level/Niveau sonore	64 dB (A)	65 dB (A)	67 dB (A)	70 dB (A)
Dimensioni Imballo/Box Dimension/Dimensions	390 x 390 x 720	570 x 570 x 1010	570 x 570 x 1010	600 x 800 x 1800
Pezzi Bancale/Pieces pallet/Pièces palette	18	8	8	1
Dimensioni Bancala/Pallet/Palette	800 x 1200 x h2400	1200 x 1200 x h2200	1200 x 1200 x h2200	800 x 1200 x h2000



 Aspirapolvere professionale con motore bistadio, studiato per l'aspirazione dei residui lasciati dagli alimenti nei forni elettrici. Il set forno opzionale, il filtro con tessuto per le alte temperature 180°, consentono l'introduzione nei forni accessi per alcuni istanti. Non idonei all'aspirazione di braci ardenti.

 Professional Dry Vacuum Cleaner with double stage motors, studied for suction of residues left by food on electric ovens. The optional oven set along with the filter for high temperatures 180°, allow the use the machines in the oven on (only for some seconds). Not suitable for suction of burning embers.

 Aspirateur professionnelle seulement poussière avec moteurs à deux étages, étudiés pour l'aspiration des résidus des aliments des les fours. Le set four optionnel, le filtre en tissu pour hautes températures 180° permettent l'introduction de l'aspirateur dans les fours pour quelques instants. Pas approprié pour l'aspiration des cendres brûlantes.



Accessori/Accessories/Accessoires		Code	
1	Tubo flessibile acciaio/Steel hose/acier flexible	Optional	KTFC25M40DBK
2	Spazzola teflon/Teflon noozle/Teflon suceur	Optional	ASPTFBK
3	Prolunga alluminio con protezione/Alluminium suction tube with protection/ Aluminium tube rallonge avec protection	Optional	KTTPABK
4	Manicottto zinc. bocchet.tang.d.50 mod. 703VF	Standard	AMLBTNG50D



Filtri/Filters/Filtre		Code	
A	Filtro tela alta temperatura /Textile filter high temperatures/Tissu filtre haute température mod. 30IBK	Standard	KFILPPI
B	Filtro tela alta temperatura/Textile filter high temperatures/Tissu filtre haute température mod. 50IMBK	Standard	KFILPMI
C	Filtro tela alta temperatura/Textile filter high temperatures/Tissu filtre haute température mod. 72IBBK/703VBK	Standard	KFILPGI
D	Tendi filtro/Filter tensioner/Tendeur de filtre Mod. 703BK	Standard	TFTPS230H345L

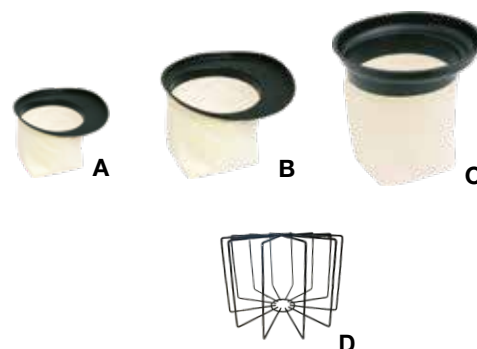





**KETEK** s.r.l.

Via E. Fermi, 5 - 25025 Manerbio (BS) - Italy

Tel. +39 030 9937068

[info@ketek.it](mailto:info@ketek.it)

[www.ketek.it](http://www.ketek.it)

